



ITT

Laing Thermotech

The DDC - The Next Generation of Laser, Computer Cooling, & Medical Pumps

Electronically Commutated Spherical Motor. 12 Volt DC Centrifugal Pumps.



- ECM – Electronically Commutated Motor
- Ultra Efficient
- Low Power Consumption
- Long Life
- Continuous Duty
- Variable Speed
- Small Footprint
- Very Quiet
- Available in AC and DC Power



The DDC - The Next Generation of Laser, Computer Cooling, & Medical Pumps

Application

The Laing DDC is the world's first pump to be used in mass produced water-cooled workstations, and presents an ideal solution for liquid cooling of processors and electronic components. Besides a lot of Online-Mentions, the Laing DDC is also awarded with the Innovation Award of BadenWürttemberg, known as one of the most innovative regions in Germany and Europe. Due to its size and output, the Laing DDC can also be used in a large number of applications.

Design

The Laing DDC is an electronically commutated spherical motor pump, with an expected service life of well over 50,000 hours.

The only moving part in a spherical motor pump is a spherically shaped rotor/impeller unit, which is seated on an ultra-hard, wear-resistant ceramic ball. The conventional shaft, shaft bearings and shaft seals have been eliminated.

The spherical bearing of the rotor/impeller unit on the ceramic ball offers a number of advantages. One such advantage is that the occurrence of bearing play and the associated increase in noise is not possible due to the principle involved. Consequently, the pump continues to work quietly throughout its entire service life. The bearing is self-realigning.

It is lubricated directly by the medium being pumped (wet rotor design). This means that the pump is maintenance free. Since the rotor is always magnetically held in the designated position, small particles of dirt do not present a problem. Under normal conditions, it is impossible for the rotor to become locked. Reliable start is also ensured even after long periods of shutdown.

The permanent magnet rotor/impeller unit is driven by the magnetic field generated by the surrounding stator. The stator is wrapped entirely around the rotor. As a result, the entire pump is only slightly taller than the rotor itself, measuring only 1.5" in height, perfect for applications where space is limited.

The spherical motor design permits economical operation with comparatively high output. Supply voltage variation provides a simple means of controlling the speed of the DDC pump over a large output range. All parts in contact with the medium are 100% corrosion resistant. With an optional tachometer output, it is possible to monitor the speed of the pump directly.



DDC Series



T: Tach Output

Blank: No Tach Output



P: Plug

Black: No Plug

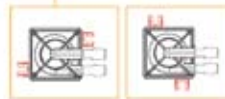

MP: Mounting Feet Parallel

MC: Mounting Feet Cross

Blank: No Mounting Feet



NPT: 1/4" NPT

Blank: 3/8" Hosebarb



Threaded DDC Pump



Standard DDC Pump



Footed DDC Pump



Center Suction
DDC Pump

The DDC - Design



Technical Data

Motor design:	Electronically commutated spherical motor
Rated voltage:	12 Volt DC
Power consumption:	DDC 3.1: max. 12 Watt, DDC 3.15: max. 12 Watt, DDC 3.2: max. 18 Watt, DDC 3.25: max. 20 Watt
Voltage range:	8 to 13,2 Volt*
Acceptable media:	Water, Water-/Glycol Mixtures**, other media on request;
Max. system pressure:	21.75 PSI
Max. system temperature:	140° F
Wetted parts:	Stainless steel 1.4571, PPS-GF40, EPDM gasket, Aluminium oxide, carbon; PA6.6 GF35

*minimum startup Voltage 9 Volt

** check pump performance for mixtures of 20% or more glycol



1/4" R Male Connection

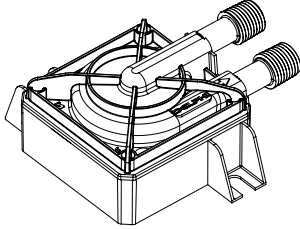
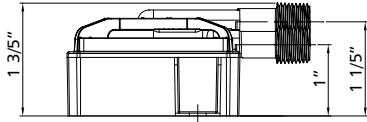

3/8" Hosebarb Connection

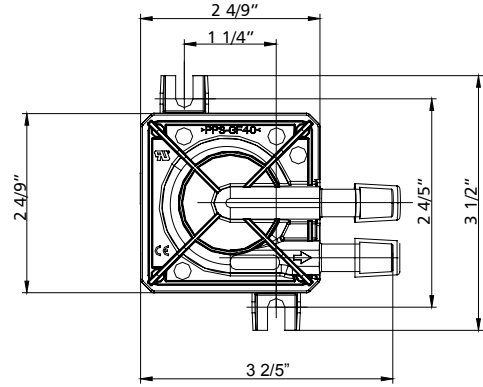
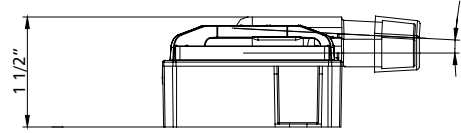
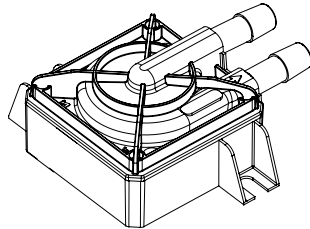
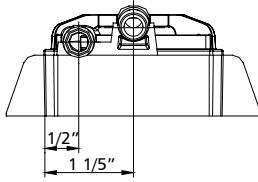

Center Suction

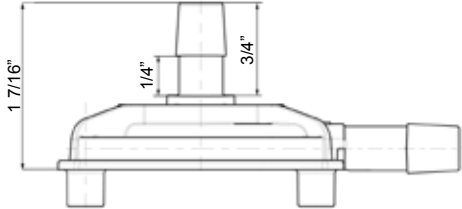

DDC Pump Family Curve

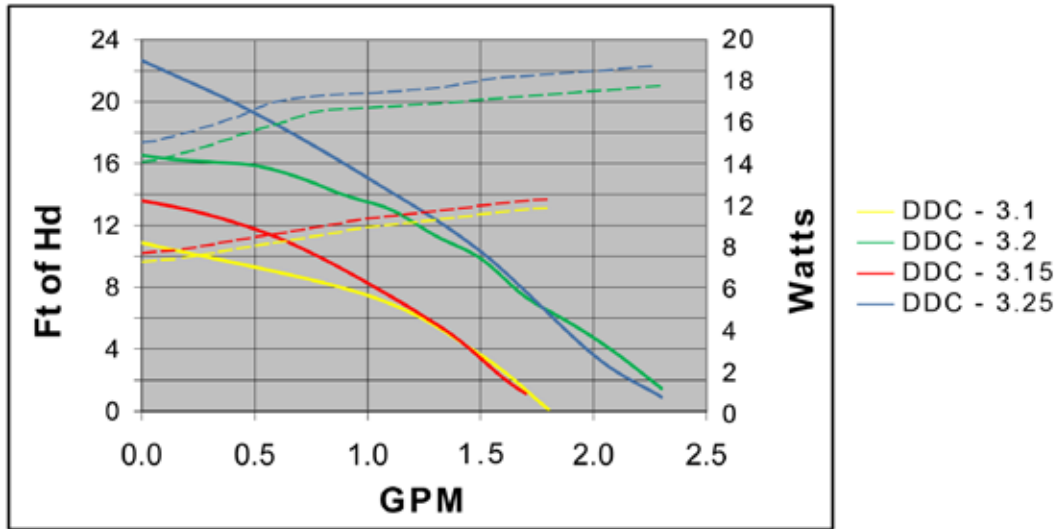

ITT
 3878 S. Willow, Suite 104
 Fresno, CA 93725
 Tel: (559) 265-4730 (800) 554-6853
 Fax: (559) 265-4740 (800) 453-7523
 www.lainginc.com



Engineered for life