

# Installation and instruction manual for Laing DDC-3 series pumps

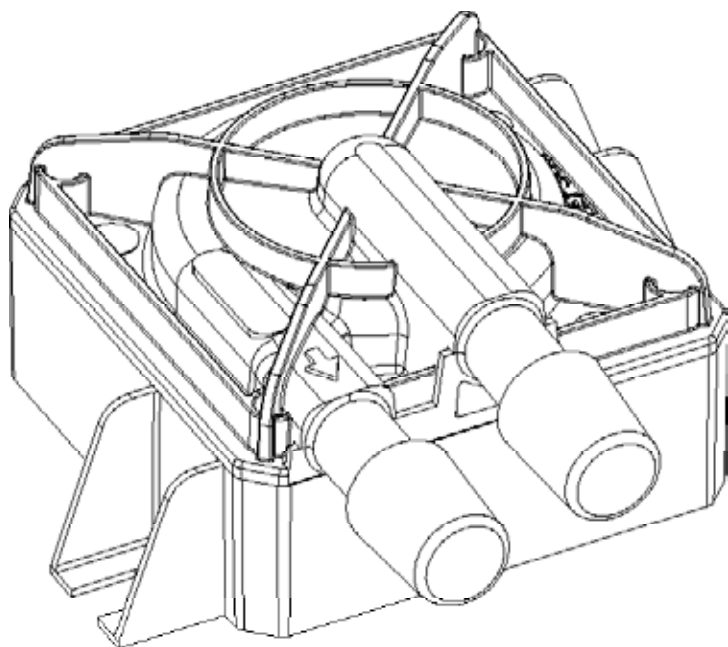

**LAING**

simply the best · by design

## Application

The Laing DDC-3 series pumps are primarily used for the circulation of cooling liquid in liquid cooled computers.

## Construction

- The Laing DDC-3 pumps are spherical motor pumps, which provide very quiet operation and long life.
- The motor is electronically commutated and the pumps consequently have a high efficiency.
- The electronic commutation creates a sine wave voltage, practically eliminating commutation noises.
- The DDC pump is supplied with and without mounting feet and either 3/8" hose barb or 1/4" male thread connections

## Installation

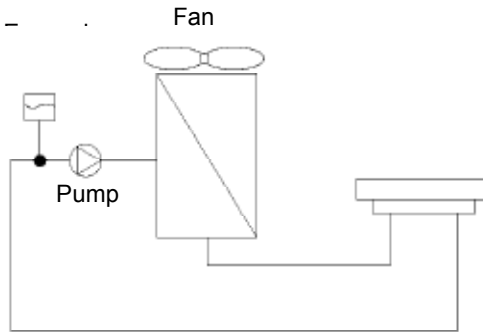

The pump is ideally installed in the cooling loop before the air cooled heat exchanger. In this way, the waste heat of the pump itself is added to the cooling loop downstream of the CPU

- An expansion tank needs to be mounted on the suction side of the pump. The expansion tank must be sized such that there is always sufficient liquid in the system.
- The pump must be mounted below the level of an open expansion tank.
- Ideally the pump should be placed at the lowest point of the system.
- The pump is mounted on a flat surface. Avoid bending the pump by over tightening of the screws.

- The pump must be mounted below the level of an open expansion tank.
- Ideally the pump should be placed at the lowest point of the system.
- The pump is mounted on a flat surface. Avoid bending the pump by over tightening of the screws.

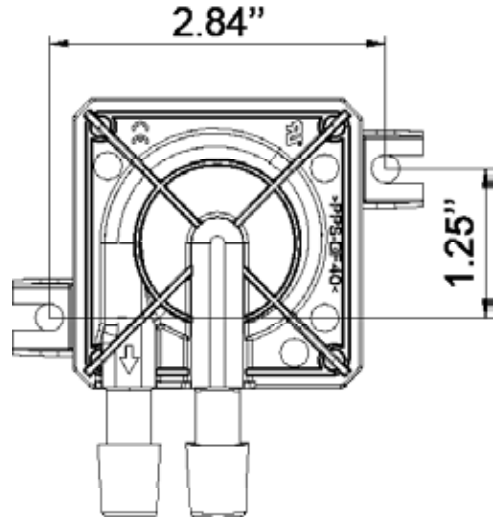

Drilling dimensions for the mounting holes (inches)

### Installation position

The pump can be mounted either to a wall or on the bottom of the computer. The pump must not be mounted with the motor pointing up and it must not be installed pumping downwards (Pump can be mounted through bottom plate with two 4mm x 10mm screws, trilobular for plastics, plastite).

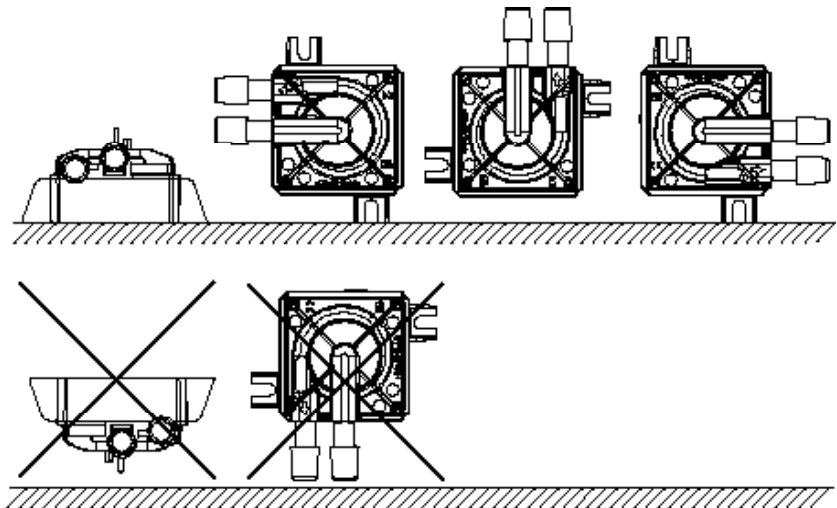

### **Electrical connection**

- The DDC pump runs on 12 Volt DC. If you install a pump without connector, make sure to observe the correct polarity.
- DDC-3P and DDC-3T are equipped with a connector for the power supply.
- The fan connector of the DDC-3T can be plugged into a fan receptacle on the motherboard to enable monitoring of the pump rpm.

### **Start-up**

- The cooling loop must be fully operational before starting the computer because the CPU otherwise can overheat in a very short time and can suffer damage.
- Before starting up the pump make sure that the loop is completely filled.
- Start the pump
- If you can hear an audible noise, air is left in the pump. Switching the pump on and off several times can accelerate the purging of this air. Disconnect the power plug and reconnect it after approx. 2 seconds.
- While purging the air observe the liquid level in the expansion tank. If the liquid in the expansion tank is exhausted, air will be sucked back into the loop continuously.
- If the system does not run quiet after several minutes of purging stop the pump and re-fill the system.
- Avoid running the pump dry for prolonged periods since this will damage the bearing.

### **Maintenance**

- The pump does not require any maintenance. There are no user replaceable parts in the pump.
- It is important for trouble free operation of the pump that there is always enough liquid in the pump, since dry run damages the bearing and leads to reduced flow or interruption of the pumping operation.
- Air in the system will cause audible noise and therefore can be easily detected.
- If there are foreign particles or deposits in the system, please follow the instructions listed in the troubleshooting section.

### Troubleshooting

- If the pump does not operate, please check first whether the power supply is operating correctly.
- If this does not resolve the problem please unplug the pump several times.
- If this still does not result in the pump starting, it is probably blocked by particles or deposits in the system.
- Drain the system and remove the pump.
- Open the pump by removing the four housing screws at the bottom.
- Remove the pump housing and pull out the rotor.
- Clean the rotor and the stator with a clean cloth and purge all dirt from the pump housing.
- After reinserting the rotor into the stator perform a brief run test to make sure that the rotor is spinning up. Caution: To avoid the introduction of water into the electronics the pump should be completely dry before this test is done.
- If the rotor is spinning in the above test, remove the o-ring from its seat and clean it carefully.
- Re-insert the seal ring, place the pump housing on top of the motor and screw it in place using the four screws.
- If the pump still won't work or if the rotor does not run during the run test the pump needs to be replaced.

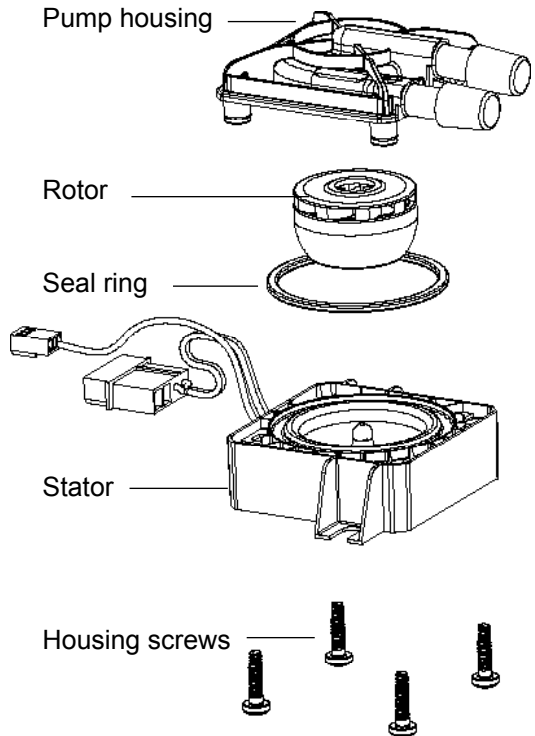

### Dimensional drawings ddc 3.1 and 3.2

With 3/8" hosebarb connection:

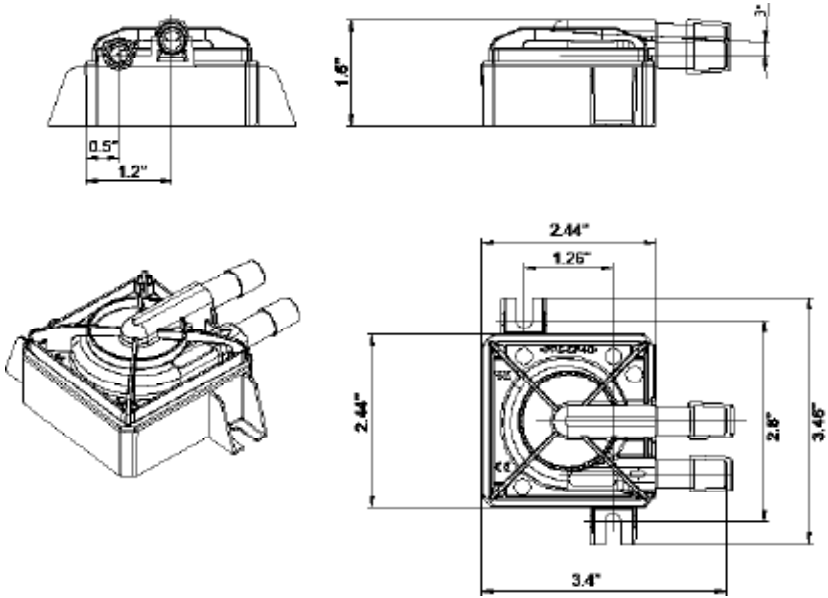

With 1/4" R male connection:

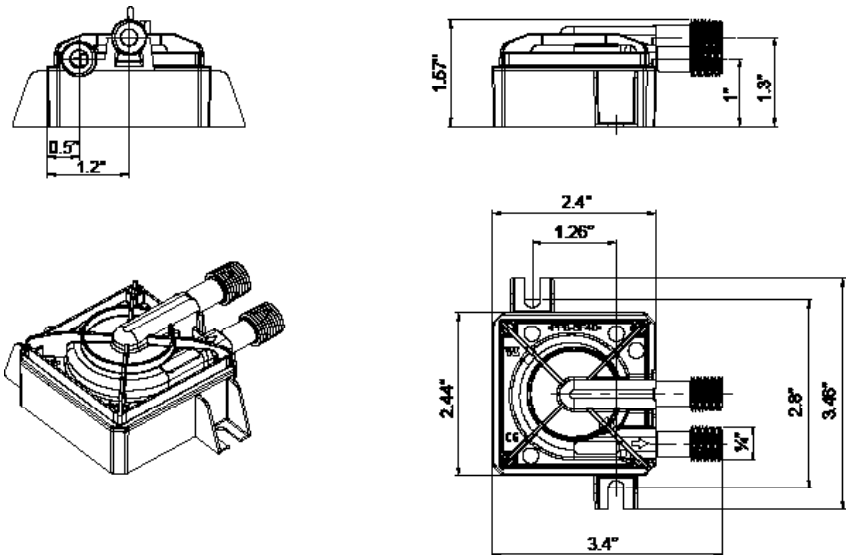

### Pump curve

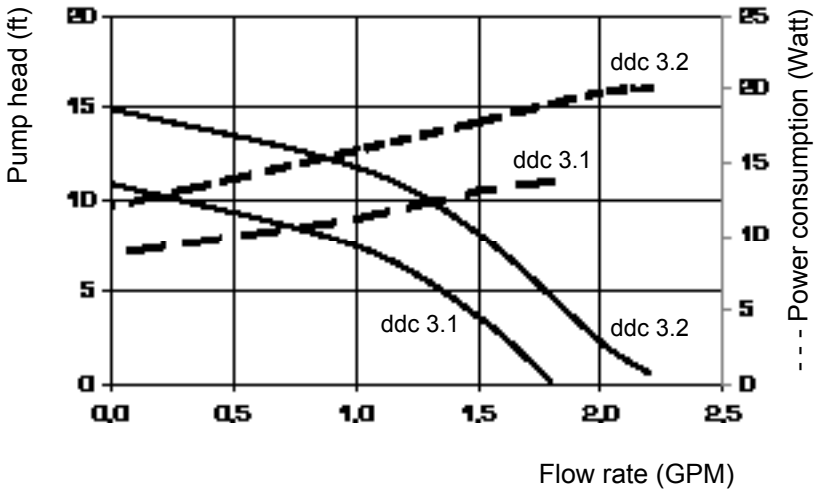

13072007 Subject to technical changes without notice.



**Laing Thermotech, Inc.**

830 Bay Blvd. Ste #101 · Chula Vista, CA 91911 · Phone: (619) 575-7466

Fax (619) 575-2739 · Technical Support: [technicalsupport@lainginc.com](mailto:technicalsupport@lainginc.com)

Customer Service: [customerservice@lainginc.com](mailto:customerservice@lainginc.com) · [www.lainginc.com](http://www.lainginc.com)